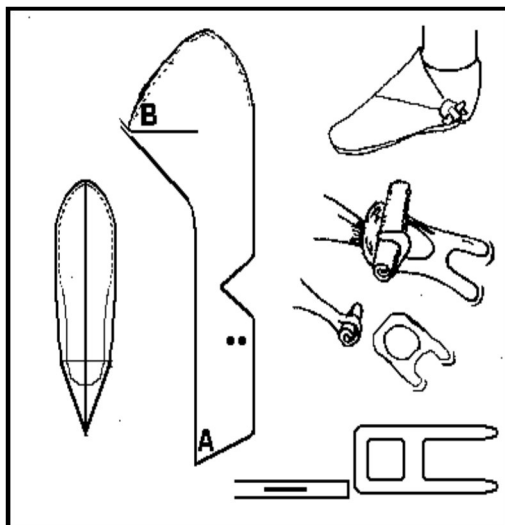

Shoe Making

loop. The toggle could also be made from bone or wood. The shoe shown is just one of several designs from the period, including one or two designs for boots.

BACK